



SINGLE REDUCTION SPEED REDUCER



GU - TYPE



Premium Speed Reducers are of substantial construction, combining rigidity with strength.

The worm is of high quality case-hardening steel, accurately generated, ground and super-finished. The worm wheel comprises a phosphor bronze centrifugally cast rim of substantial section welded to a rigid centre, which is pressed and keyed to the shaft.

Shafts are located on dual purpose bearings of ample capacity and having a substantial margin on output shafts for accommodating overhung loads. Lubrication is positive at all speeds, in either direction of rotation and apart from an occasional oil check, no attention is necessary in service.

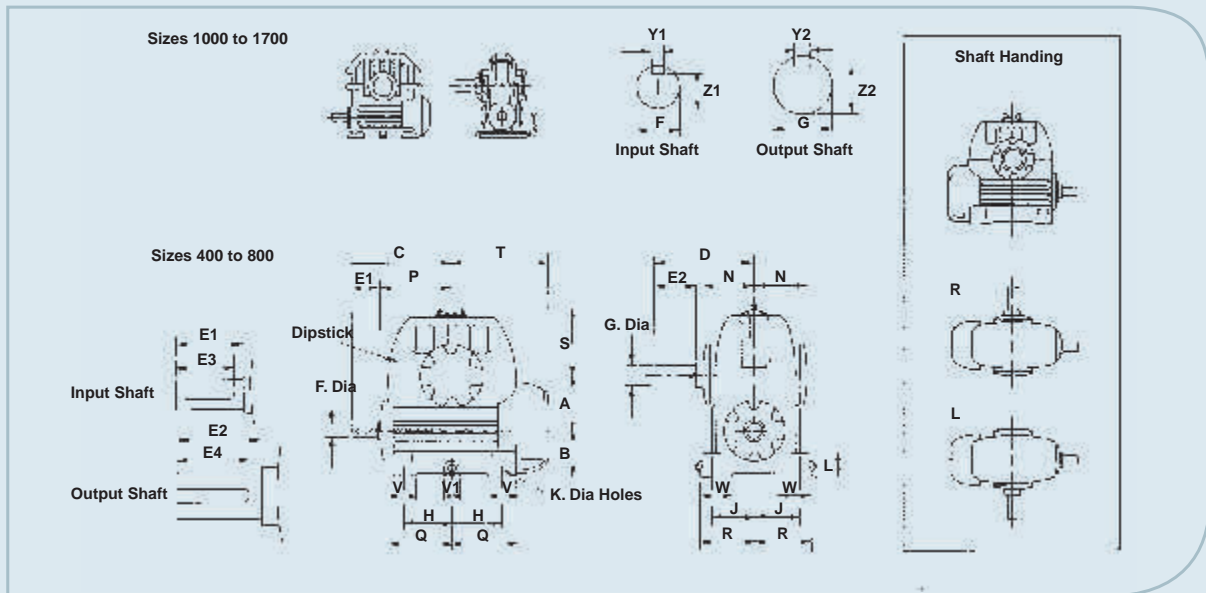

Principal Dimensions (mm)

SIZE	A	B	C	D	E1	E2	E3	E4	F	G	H	J	K
400	101.6	108.0	229	216	67	89	54	83	31.750 31.735	44.450 44.435	108.0	101.6	20.6
500	127.0	114.3	260	248	73	102	73	95	38.100 38.085	50.800 50.782	123.8	111.1	20.6
600	152.4	127.0	279	273	76	114	73	114	38.100 38.085	57.150 57.135	133.4	120.7	23.8
700	177.8	146.1	318	298	86	127	83	114	44.450 44.435	63.500 63.482	152.4	133.4	23.8
800	203.2	146.1	343	311	89	140	83	127	44.450 44.435	69.850 69.832	171.5	133.4	27.0
1000	254.0	171.5	425	375	121	152	89	143	57.150 57.135	82.550 82.527	215.9	165.1	31.8
1200	304.8	190.5	495	413	124	171	89	162	63.500 63.482	95.250 95.227	260.4	184.2	34.9
1400	355.6	215.9	572	483	149	191	146	210	76.200 76.182	114.300 114.277	298.5	215.9	41.3
1700	431.8	254.0	699	546	181	203	152	222	82.550 82.527	139.700 139.675	381.0	254.0	41.3



SIZE	L	N	P	Q	R	S	T	V	V1	W	Y1	Y2	Z1	Z2
400	44	121	159	140	127	137	222	64	-	76	7.976 7.925	11.176 11.125	34.47 34.24	47.73 47.50
500	54	133	184	164	137	159	254	70	-	83	9.576 9.525	12.751 12.700	40.72 40.49	53.98 53.75
600	64	140	200	179	149	184	270	76	-	89	9.576 9.525	15.926 15.875	40.72 40.49	61.75 61.52
700	70	151	229	208	162	210	305	89	-	98	11.176 11.125	15.926 15.875	47.73 47.50	68.10 67.87
800	76	159	251	230	171	235	327	102	-	102	11.176 11.125	19.101 19.050	47.73 47.50	75.03 74.80
1000	51	194	311	298	200	292	378	127	64	200	15.926 15.875	22.276 22.225	61.75 61.52	89.13 88.87
1200	57	216	368	356	222	343	441	152	76	222	15.926 15.875	25.476 25.400	68.10 67.87	103.20 102.95
1400	64	254	425	413	260	394	521	178	89	260	19.101 19.050	31.826 31.750	81.38 81.15	123.47 123.22
1700	76	305	514	502	298	489	629	191	127	298	22.276 22.225	38.202 38.100	89.13 88.90	150.04 149.73

STANDARD NOMINAL RATIOS													
400	5	7.5	10	12.5	15	20	25	30	-	40	50	60	70
500	5	7.5	10	-	15	20	25	30	35	40	50	60	70
600	5	7.5	10	-	15	20	25	30	35	40	50	60	70
700	5	7.5	10	-	15	20	25	30	35	40	50	60	70
800	5	7.5	10	-	15	20	25	30	-	40	50	60	70
1000	5	7.5	10	-	15	20	25	30	-	40	50	60	70
1200	5	7.5	10	12.5	15	20	25	30	35	40	50	60	70
1400	5	7.5	10	12.5	15	20	25	30	-	40	50	60	70
1700	-		10	-	15	20	25	30	-	40	50	60	70

Approximate Shipping Specification and Oil Capacities

Size	400	500	600	700	800	1000	1200	1400	1700
Net weight (kg)	68	95	125	172	218	350	540	864	1340
Gross weight (kg)	79	109	140	191	244	395	635	928	1440
Volume packed (cu. m.)	.08	.12	.15	.21	.27	.48	.76	1.1	1.7
Oil required at 1st filling (lit)	3.0	4.3	6.3	9.1	11.4	15.9	22.7	36.4	45

As improvements in design are continually being made, this specification is not regarded as binding in detail, and dimensions are subject to alteration without notice.



GV - TYPE



Premium Speed Reducers are of substantial construction, combining rigidity with strength.

The worm is of high quality case-hardening steel, accurately generated, ground and super-finished. The worm wheel comprises a phosphor bronze centrifugally cast rim of substantial section welded to a rigid centre, which is pressed and keyed to the shaft.

Shafts are located on dual purpose bearings of ample capacity and having a substantial margin on output shafts for accommodating overhung loads. Lubrication is positive at all speeds, in either direction of rotation and apart from an occasional oil check, no attention is necessary in service. Units are handed 'R' and 'L' with the suffix 'X' or 'Y' denoting position of slow speed shaft extension.

These are shown in the diagrams on the following page and references should be quoted when ordering.

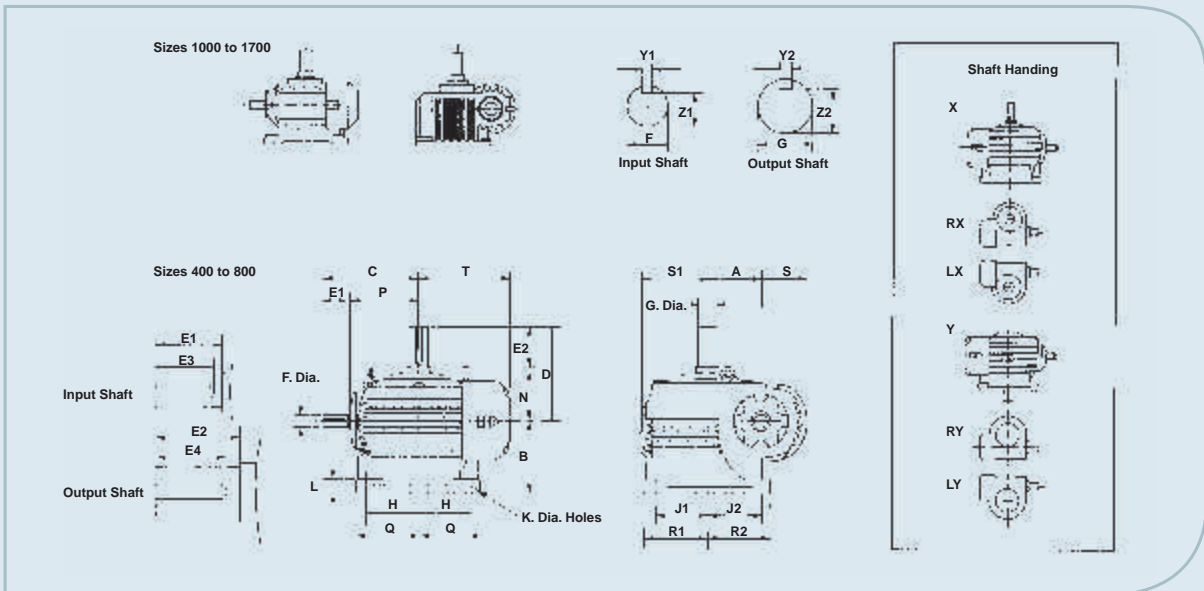

Principal Dimensions (mm)

SIZE	A	B	C	D	E1	E2	E3	E4	F	G	H	J1	J2	K
400	101.6	171.5	229	216	67	89	54	83	31.750 31.735	44.450 44.435	114.3	114.3	114.3	20.6
500	127.0	190.5	260	248	73	102	73	95	38.100 38.085	50.800 50.782	139.7	139.7	139.7	20.6
600	152.4	209.6	279	273	76	114	73	114	38.100 38.085	57.150 57.135	152.4	152.4	152.4	23.8
700	177.8	228.6	318	298	86	127	83	114	44.450 44.435	63.500 63.482	177.8	177.8	177.8	23.8
800	203.2	241.3	343	311	89	140	83	127	44.450 44.435	69.850 69.832	203.2	203.2	203.2	27.0
1000	254.0	279.4	425	375	121	152	89	143	57.150 57.135	82.550 82.527	260.4	260.4	235.0	31.8
1200	304.8	304.8	495	413	124	171	89	162	63.500 63.482	95.250 95.227	317.5	317.5	266.7	34.9
1400	355.6	330.2	572	483	149	191	146	210	76.200 76.182	114.300 114.277	355.6	355.6	304.8	41.3
1700	431.8	406.4	699	546	181	203	152	222	82.550 82.527	139.700 139.675	431.8	431.8	431.8	41.3



SIZE	L	N	P	Q	R1	R2	S	S1	T	Y1	Y2	Z1	Z2
400	32	121	159	140	140	140	111	152	222	7.976 7.925	11.176 11.125	34.47 34.24	47.73 47.50
500	32	133	184	165	165	165	124	178	254	9.576 9.525	12.751 12.700	40.72 40.49	53.98 53.75
600	38	140	200	184	184	184	133	197	270	9.576 9.525	15.926 15.875	40.72 40.49	61.75 61.52
700	38	151	229	210	210	210	143	222	305	11.176 11.125	15.926 15.875	47.73 47.50	68.10 67.87
800	44	159	251	238	238	238	149	254	327	11.176 11.125	19.101 19.050	47.73 47.50	75.03 74.80
1000	51	194	311	311	299	273	160	298	378	15.926 15.875	22.276 22.225	61.75 61.52	89.13 88.87
1200	57	216	368	368	356	305	177	356	441	15.926 15.875	25.476 25.400	68.10 67.87	103.20 102.95
1400	64	254	425	425	413	362	203	413	521	19.101 19.050	31.826 31.750	81.38 81.15	123.47 123.22
1700	76	305	514	502	502	502	241	502	629	22.276 22.225	38.202 38.100	89.13 88.90	150.04 149.73

STANDARD NOMINAL RATIOS													
400	5	7.5	10	12.5	15	20	25	30	-	40	50	60	70
500	5	7.5	10	-	15	20	25	30	35	40	50	60	70
600	5	7.5	10	-	15	20	25	30	35	40	50	60	70
700	5	7.5	10	-	15	20	25	30	35	40	50	60	70
800	5	7.5	10	-	15	20	25	30	-	40	50	60	70
1000	5	7.5	10	-	15	20	25	30	-	40	50	60	70
1200	5	7.5	10	12.5	15	20	25	30	35	40	50	60	70
1400	5	7.5	10	12.5	15	20	25	30	-	40	50	60	70
1700	-	-	10	-	15	20	25	30	-	40	50	60	70

Approximate Shipping Specification and Oil Capacities

Size	400	500	600	700	800	1000	1200	1400	1700
Net weight (kg)	77	109	145	200	254	465	690	970	1750
Gross weight (kg)	90	125	163	226	286	580	830	1250	2100
Volume Wheelshaft up	.12	.17	.21	.28	.44	1.0	1.4	1.9	2.8
packed (cu.m.)-wheelshaft down	.11	.15	.19	.25	.39	.9	1.3	1.75	2.6
Oil required at 1st filling (lit.)	4.0	5.7	6.3	10.2	12.5	22.7	37.4	68.5	105

As improvements in design are continually being made, this specification is not regarded as binding in detail, and dimensions are subject to alteration without notice.



GO - TYPE



Premium Speed Reducers are of substantial construction, combining rigidity with strength.

The worm is of high quality case-hardening steel, accurately generated, ground and super-finished. The worm wheel comprises a phosphor bronze centrifugally cast rim of substantial section welded to a rigid centre, which is pressed and keyed to the shaft.

Shafts are located on dual purpose bearings of ample capacity and having a substantial margin on output shafts for accommodating overhung loads. Lubrication is positive at all speeds, in either direction of rotation and apart from an occasional oil check, no attention is necessary in service.

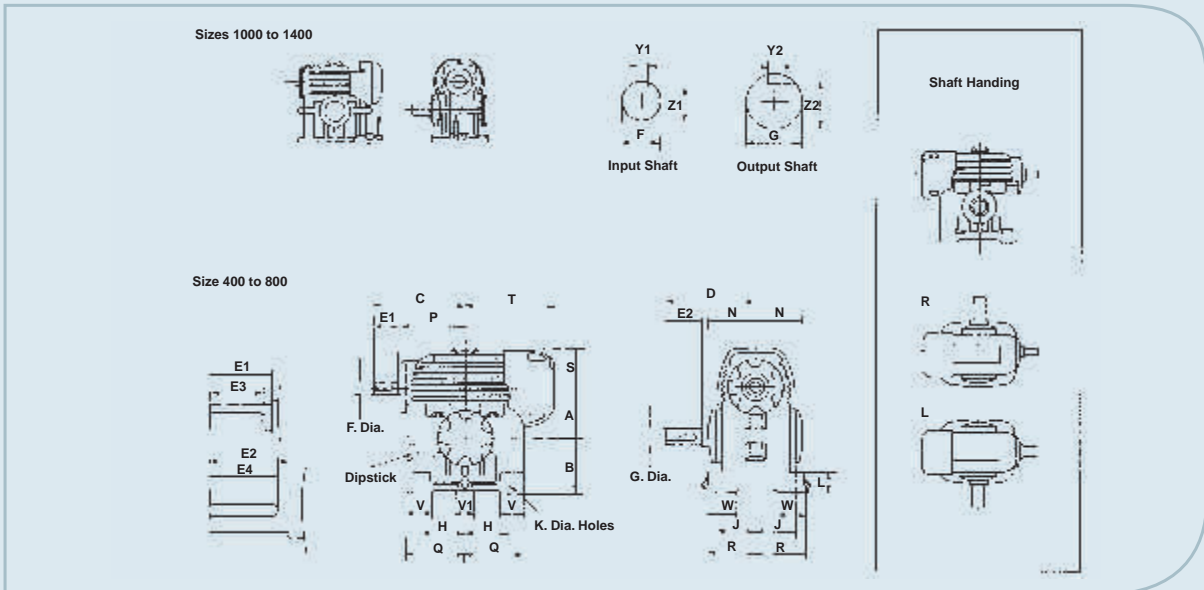

Principal Dimensions (mm)

SIZE	A	B	C	D	E1	E2	E3	E4	F	G	H	J	K
400	101.6	120.7	229	216	67	89	54	83	31.750 31.735	44.450 44.435	108.0	101.6	20.6
500	127.0	146.1	260	248	73	102	73	95	38.100 38.085	50.800 50.782	123.8	111.1	20.6
600	152.4	171.5	279	273	76	114	73	114	38.100 38.085	57.150 57.135	133.4	120.7	23.8
700	177.8	196.9	318	298	86	127	83	114	44.450 44.435	63.500 63.482	152.4	133.4	23.8
800	203.2	222.3	343	311	89	140	83	127	44.450 44.435	69.850 69.832	171.5	133.4	27.0
1000	254.0	273.1	425	375	121	152	89	143	57.150 57.135	82.550 82.527	215.9	165.1	31.8
1200	304.8	330.2	495	413	124	171	89	162	63.500 63.482	95.250 95.227	260.4	184.2	34.9
1400	355.6	381.0	572	483	149	191	146	210	76.200 76.182	114.300 114.277	298.5	215.9	41.3



SIZE	L	N	P	Q	R	S	T	V	V1	W	Y1	Y2	Z1	Z2
400	44	121	159	140	127	108	222	64	-	76	7.976 7.925	11.176 11.125	34.47 34.24	47.73 47.50
500	54	133	184	164	137	117	254	70	-	83	9.576 9.525	12.751 12.700	40.72 40.49	53.98 53.75
600	64	140	200	179	149	124	270	76	-	89	9.576 9.525	15.926 15.875	40.72 40.49	61.75 61.52
700	70	151	229	208	162	165	305	89	-	98	11.176 11.125	15.926 15.875	47.73 47.50	68.10 67.87
800	76	159	251	230	171	165	327	102	-	102	11.176 11.125	19.101 19.050	47.73 47.50	75.03 74.80
1000	51	194	311	298	200	191	378	127	64	200	15.926 15.875	22.276 22.225	61.75 61.52	89.13 88.87
1200	57	216	368	356	222	203	441	152	76	222	15.926 15.875	25.476 25.400	68.10 67.87	103.20 102.95
1400	64	254	425	413	260	229	521	178	89	260	19.101 19.050	31.826 31.750	81.38 81.15	123.47 123.22

STANDARD NOMINAL RATIOS													
400	5	7.5	10	12.5	15	20	25	30	-	40	50	60	70
500	5	7.5	10	-	15	20	25	30	35	40	50	60	70
600	5	7.5	10	-	15	20	25	30	35	40	50	60	70
700	5	7.5	10	-	15	20	25	30	35	40	50	60	70
800	5	7.5	10	-	15	20	25	30	-	40	50	60	70
1000	5	7.5	10	-	15	20	25	30	-	40	50	60	70
1200	5	7.5	10	12.5	15	20	25	30	35	40	50	60	70
1400	5	7.5	10	12.5	15	20	25	30	-	40	50	60	70
1700	-	-	10	-	15	20	25	30	-	40	50	60	70

Approximate Shipping Specification and Oil Capacities

Size	400	500	600	700	800	1000	1200	1400
Net weight (kg)	71	98	130	177	225	355	550	886
Gross weight (kg)	79	109	140	191	244	395	635	928
Volume packed (cu. m.)	.08	.12	.15	.21	.27	.48	.76	1.1
Oil required at 1st filling (lit)	3.0	4.3	6.3	9.1	11.4	15.9	22.7	36.4

As improvements in design are continually being made, this specification is not regarded as binding in detail, and dimensions are subject to alteration without notice.



PREMIUM

Premium Energy Transmission Limited

Head Office : P.B. No. 5, Chinchwad, Pune - 411 019, India.
Tel. : (91-20) 27475141/42/43/44, Fax : (91-20) 27450287, 27476601.
Website : www.premiumtransmission.com

Branch Offices :

Western Region :

Mumbai : Industry Manor, Appasaheb Marathe Marg, Prabhadevi, Mumbai - 400 025.
Tel. : (91-22) 24223747, 24365510, Fax : (91-22) 24377730.

Ahmedabad : "Jaldarshan", Ashram Road, Navrangpura, Ahmedabad - 380 009.
Tel. : (91-79) 26580428/0518/1861, Fax : (91-79) 26587783.

Nagpur : "Guman", Pandit Jawaharlal Nehru Marg, Sadar, P. B. No. 129, Nagpur - 440 001.
Tel. : (91-712) 2526588, 2524125, 2526038, Fax : (91-712) 2541142.

Northern Region :

New Delhi : Express Building Annexe, 9-10, Bahadur Shah Zafar Marg, New Delhi - 110 002.
Tel. : (91-11) 23730554 (8 lines), Fax : (91-11) 23359782.

Eastern Region :

Kolkata : Thapar House, 25, Brabourne Road, P. B. No. 702, Kolkata - 700 001.
Tel. : (91-33) 22423811, 22423780, 22423805, Fax : (91-33) 22424325.

Ranchi : Rani Kuthi, 82, Burdwan Compound, P.B. No. 139, Ranchi - 834 001.
Tel. : (91-651) 2562651, Fax : (91-651) 2562027.

Southern Region :

Chennai : "Wavoo Mansion", 6th Floor, New No. 48, (Old No. 39), Rajaji Salai, Chennai - 600 001.
Tel. : (91-44) 25240142, Fax : (91-44) 25224557.

Bangalore : 16/3, Ali Asker Road, P. B. No. 216, Bangalore - 560 052.
Tel. : (91-80) 22268773/2506, Fax : (91-80) 22253472.

Hyderabad : 6-2-47, A. C. Guards, 1st floor, P. B. No. 9, Hyderabad - 500 004.
Tel. : (91-40) 23314025, 23390544, 23316446, Fax : (91-40) 23318557.

Kochi : 39/5567, M. G. Road, Ernakulam, Kochi - 682 015.
Tel. : (91-484) 2359190, 2359372, Telefax : (91-484) 2359589.

